

Harilla Landing Yacht Club Boat Measurement Policy

Each indoor storage unit (A,B,C,D,E) at HLYC has deeded length, width, height and weight limits. The following diagrams show how HLYC measures boats. Boats valeted during the summer in indoor units must not exceed any of these limits.

Boats on floating and private dock units (O) must not exceed their deeded length dimension. Boat widths for floating docks must not exceed 50% of total width with an adjacent floating dock unit unless a written agreement stating otherwise is reached between neighbors.

The HLYC BOD reserves the right to assess watercraft configurations not shown in this document on a case by case basis.

Weight

HLYC will use the manufacturer's dry weight specification to determine acceptability.

Length Overall (LOA)

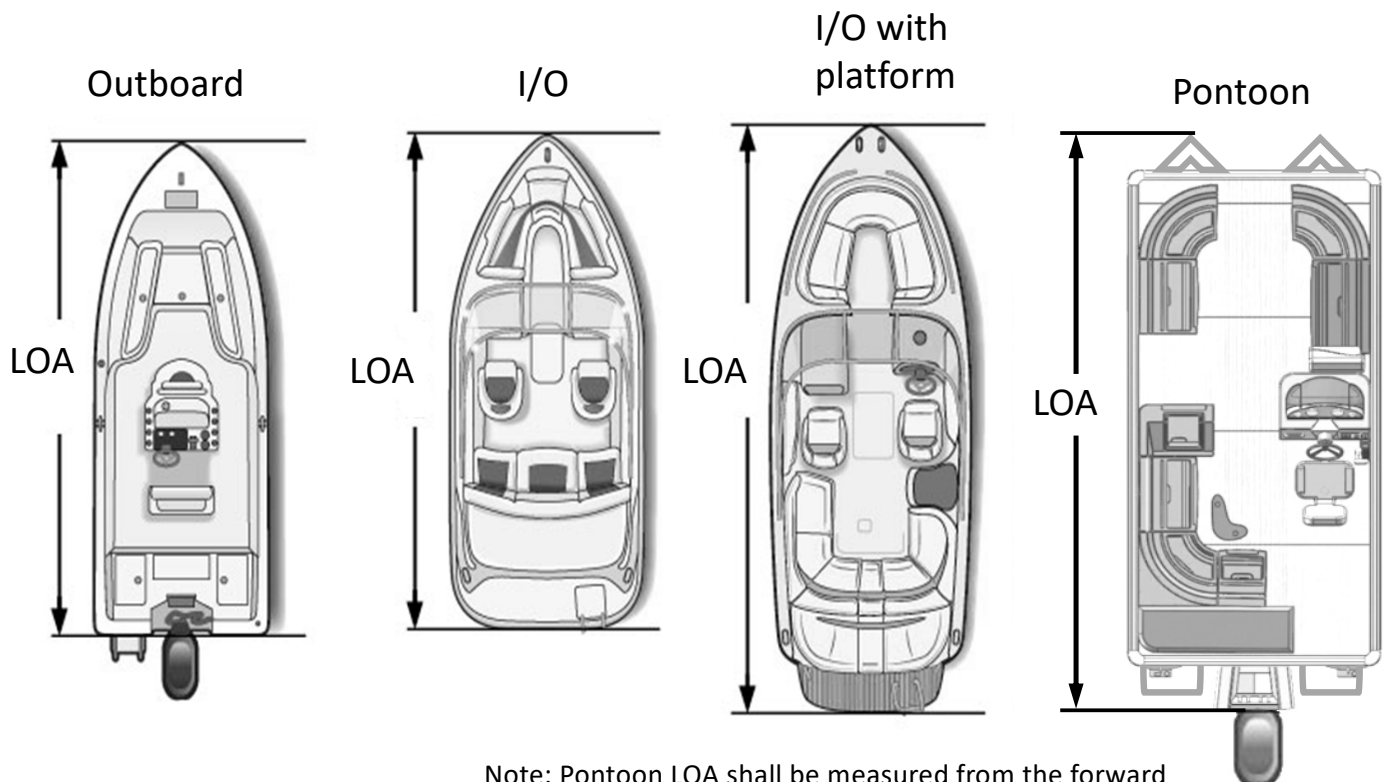

Note: Pontoon LOA shall be measured from the forward most feature to the aft most feature not to include the engine. Tri-toons are not compatible with HLYC forklifts and therefore not accepted for valet service.

Height (H)

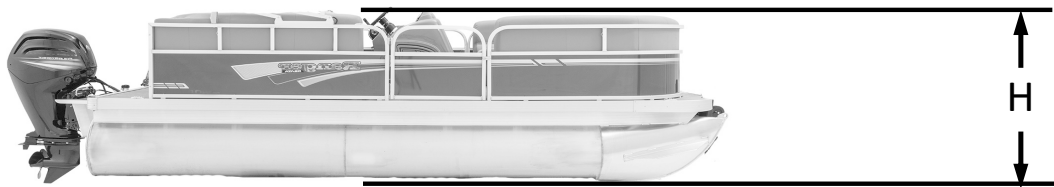

Note: Height measurement is made from the bottom of the keel to the highest point above deck. Unless tops or enclosures are stowed before each storage, they will be included in the height measurement.

Width (W)

Vee or tri-hull

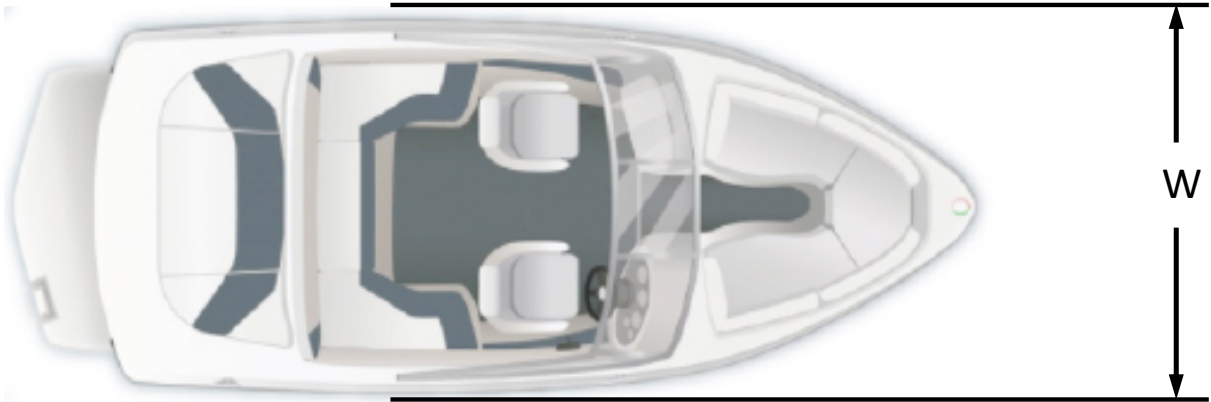

Pontoon

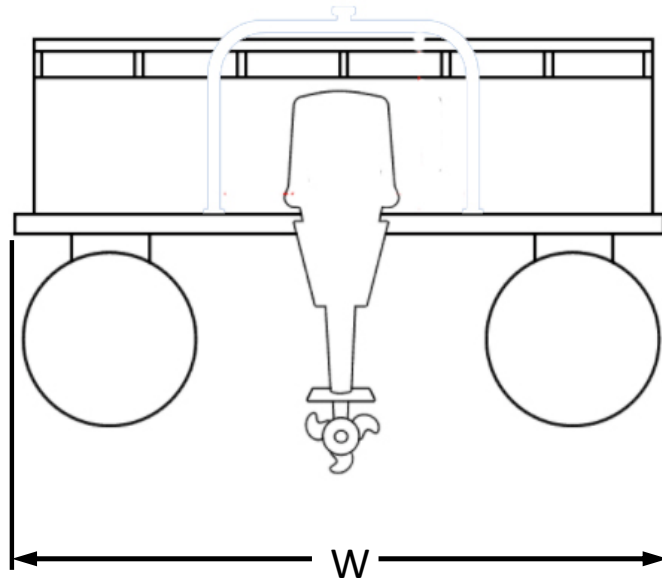

Note: Any boat exceeding 102” in total width may exceed safe valet storage limits and must be discussed with the Board of Directors prior to approval.